

Shop-floor Type CNC Coordinate Measuring Machine MiSTAR 555



Production ready for near-line or in-line operation on the shop floor



Coordinate Measuring Machines



Highly Environment-resistant Coordinate Measuring Machine, Allowing Shop-floor Inspection outside the Measuring Room

- The MiSTAR has an accuracy guaranteed temperature range of 10 to 40°C by incorporating a combination of technologies such as a symmetric structure, uniform material, and temperature compensation.
- The MiSTAR achieves a contamination resistance more than 2 times better than conventional CMM's by implementing the newly developed Mitutoyo absolute scale* that is highly resistant to the challenging productionline environment.
 - * A scale that provides an absolute value for each measurement point. This eliminates the need for a machine initialization operation.
- The MiSTAR features a single support moving bridge and a storage cabinet for all machine controllers under the measuring table to save installation space. This has reduced the footprint to about 70% compared with that of the conventional moving bridge model.

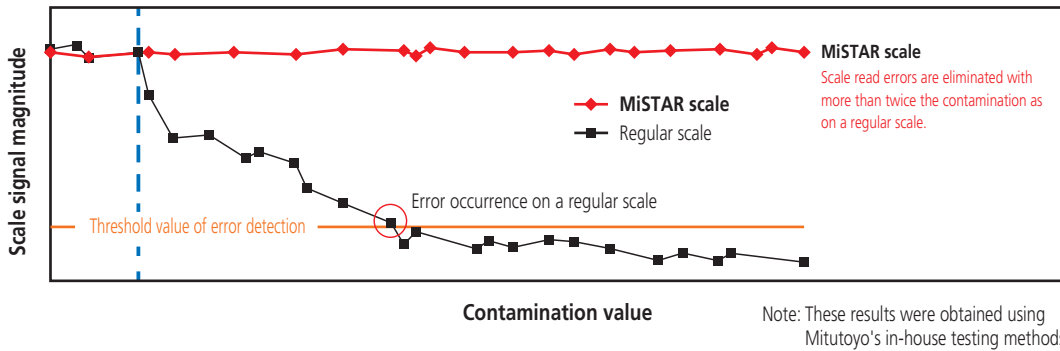

User-friendly Design Reduces Operator's Workload

- The adoption of single support moving bridge provides a three-sided open architecture, significantly easing the task of moving workpieces on and off the measuring table.
- With Mitutoyo clamping tools and pallet receiver designed for the MiSTAR enables quick setup and measurement of like workpieces.
- The use of clamping tools and pallet receiver enables quick measurement of similar workpieces.

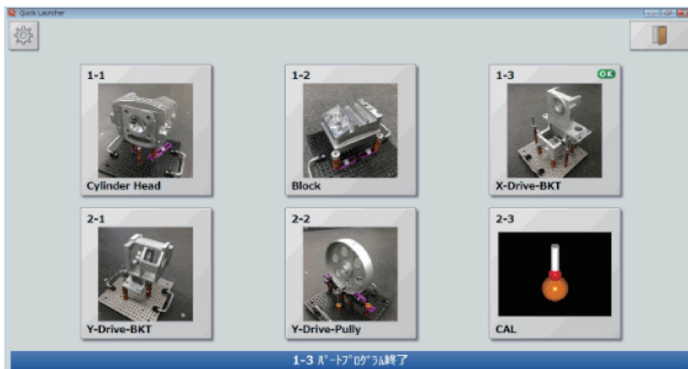

Quick Launcher

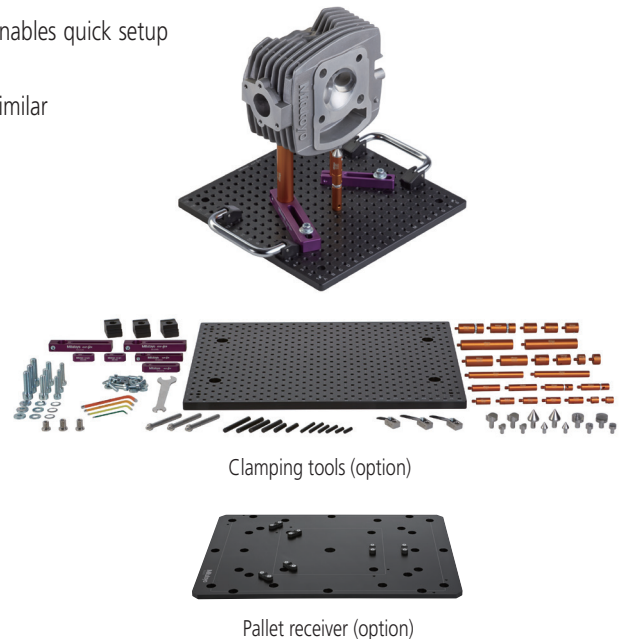

New Functionality has the "Smart Factory" in View

- From status control to preventive maintenance. Smart Factory starts with "visualization".
- MiSTAR 555 is compatible with the following three applications that consolidate information management of the manufacturing process through a network.

Status Monitor: Allows remote monitoring of the operational status of measuring instruments.

Condition Monitor*1: Allows remote monitoring of the current condition and historical data of measuring instruments.

MeasurLink*1: Reduces the production of defective parts through "Visualizing Quality".

*1: Optional



SMS (Smart Measuring System)

This system allows on-line monitoring of the operational status of a measuring machine and visualization of measurement data produced during the manufacturing process to enable product quality improvement.

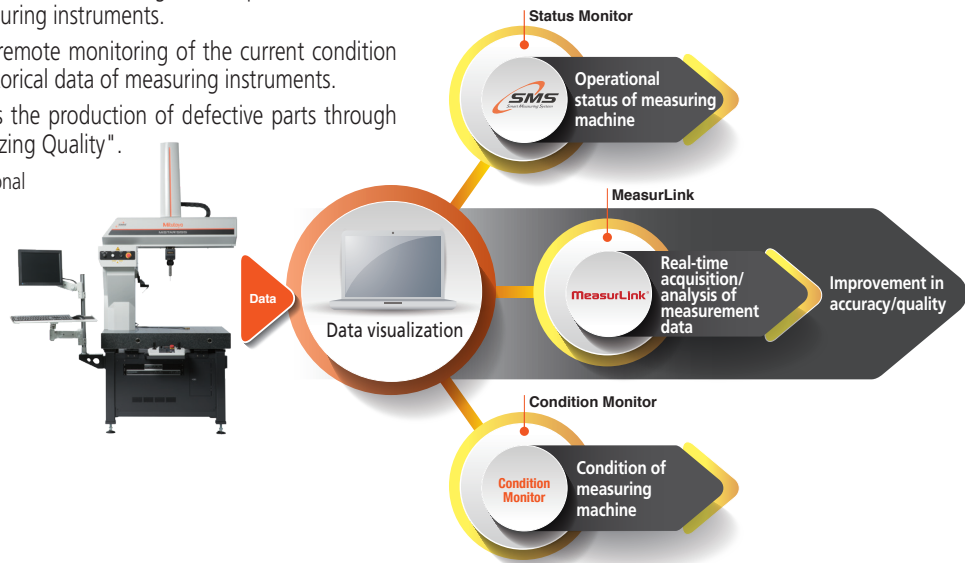

SPECIFICATIONS

		MiSTAR 555
Measuring range	X	22.4" (570mm)
	Y	19.6" (500mm)
	Z	19.6" (500mm)
Max. Permissible Length Measurement Error (ISO 10360-2: 2009)*2	64.4~7.16°F (18~22°C)	(2.2 + 3.0L/1000)µm
	50.0~86.0°F (10~30°C)	(2.9 + 4.5L/1000)µm
	50.0~104.0°F (10~40°C)	(3.8 + 8.0L/1000)µm
Drive speed (3D)		606mm/s in CNC MODE
Drive acceleration (3D)		2695 mm/s ²
Measuring table capacity	Maximum workpiece height	25.9" (660mm)
	Maximum loading	264.5 lbs. (120kg)
Mass (includes machine controller)		1,444 lbs. (655kg)

*2: SP25M probe, specifications vary by configuration and thermal environment.

DIMENSIONS (unit: mm)

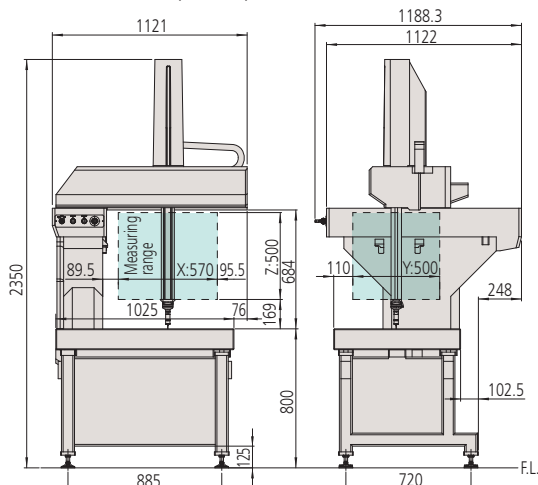

Equipped with the PH6M probe head



Equipped with the PH10MQ probe head



Whatever your challenges are, Mitutoyo supports you from start to finish.

Mitutoyo is not only a manufacturer of top quality measuring products but one that also offers qualified support for the lifetime of the equipment, backed up by comprehensive services that ensure your staff can make the very best use of the investment.

Apart from the basics of calibration and repair, Mitutoyo offers product and metrology training, as well as IT support for the sophisticated software used in modern measuring technology. We can also design, build, test and deliver measuring solutions and even, if deemed cost-effective, take your critical measurement challenges in-house on a sub-contract basis.



Find additional product literature and our product catalog

www.mitutoyo.com

Note: All information regarding our products, and in particular the illustrations, drawings, dimensional and performance data contained in this printed matter as well as other technical data are to be regarded as approximate average values. We therefore reserve the right to make changes to the corresponding designs. The stated standards, similar technical regulations, descriptions and illustrations of the products were valid at the time of printing. In addition, the latest applicable version of our General Trading Conditions will apply. Only quotations submitted by ourselves may be regarded as definitive. Specifications are subject to change without notice.

Mitutoyo products are subject to US Export Administration Regulations (EAR). Re-export or relocation of our products may require prior approval by an appropriate governing authority.

Trademarks and Registrations

Designations used by companies to distinguish their products are often claimed as trademarks. In all instances where Mitutoyo America Corporation is aware of a claim, the product names appear in initial capital or all capital letters. The appropriate companies should be contacted for more complete trademark and registration information.



Mitutoyo America Corporation

www.mitutoyo.com
 One Number to Serve You Better
 1-888-MITUTOYO (1-888-648-8869)

M³ Solution Centers:

- Aurora, Illinois (Headquarters)
- Boston, Massachusetts
- Huntersville, North Carolina
- Mason, Ohio
- Detroit Michigan
- City of Industry, California
- Birmingham, Alabama
- Renton, Washington
- Houston, Texas